

# iGarden

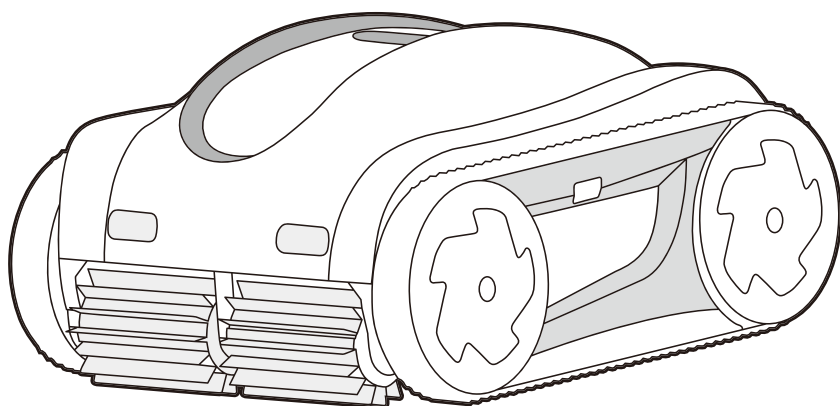

## iGarden Pool Cleaner K Pro

— USER MANUAL —

Please read this manual carefully before installing and operating your pool cleaner, and keep this manual for future reference to ensure safe and effective use.

---

# Table of Contents

**1 Introduction** 01

**2 Important Safety Information** 01

2.1 General Warnings

2.2 Operating Conditions

**3 What's in the Box** 02

**4 Getting Started** 03

4.1 Charge

4.2 Power On

4.3 Go

4.4 Deploy

4.5 Prepare

**5 Connecting Your Cleaner** 05

5.1 Before you begin

5.2 Pairing the robot

**6 Using Your Cleaner** 07

6.1 Control Panel Overview

6.2 Control Panel Details

---

**7 Care & Cleaning**

08

**8 Troubleshooting**

12

**9 Technical Specifications**

13

**10 Regulatory & Compliance**

14

**11 Warranty**

15

**12 Support**15

---

---

# 1 Introduction

Thank you for choosing the iGarden Pool Cleaner K Pro. This guide leads you through setup, operation, maintenance, and support—so you can dive in and enjoy crystal-clear water.

## 2 Important Safety Information

**Read all instructions before use. Ignoring safety guidelines may cause injury, property damage, or void your warranty.**

### 2.1 General Warnings

- For pool cleaning use only. Do not use for any other purpose.
- Read the user manual carefully before operation.
- Children and individuals with reduced physical, sensory, or mental capabilities should only use the device under supervision and instruction.
- Keep children and pets away during operation.
- Install and operate the device according to the manual. Improper setup may result in malfunction or void the warranty.
- Do not enter the pool while the cleaner is running.
- Always switch the device off before lifting, carrying, or connecting the battery.
- Only use the designated battery and charger provided by the manufacturer.
- Do not use damaged or modified batteries or devices.
- Keep batteries away from metal objects such as keys, coins, or clips to prevent short circuit.
- Store the battery in a dry, safe place when not in use.
- If battery fluid leaks and comes into contact with skin, rinse with water. If contact occurs with eyes, seek immediate medical attention.
- Charge only within the specified temperature range.
- Do not expose the cleaner or battery to fire or temperatures above 130° C / 265° F.

- Service must be performed by qualified personnel using identical replacement parts only.

## 2.2 Operating Conditions

Parameter	Range
Water depth	1 – 2.5 m / 3.3 – 8.2 ft
Water temperature	4 – 35 °C / 39.2 – 95 °F
pH level	7.0 – 7.8
Salt (NaCl)	≤ 5000 ppm
Free chlorine	≤ 4 ppm
IP rating	IPX8

## 3 What's in the Box

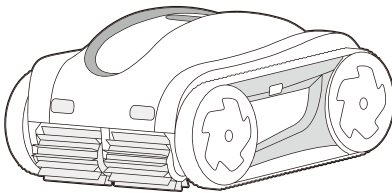

iGarden Pool Cleaner K Series

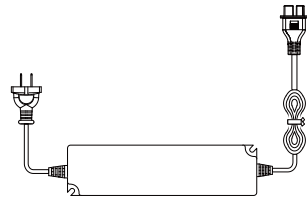

Charger

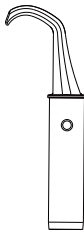

Retrieval Hook

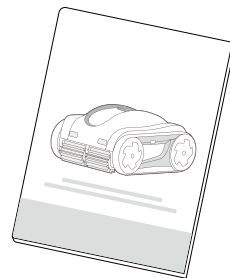

User Manual

---

## 4 Getting Started

**4.1 Charge:** Open port cover, connect charger to mains (100–240 V AC). Three green LEDs = full. Once fully charged, replace the plug cover.

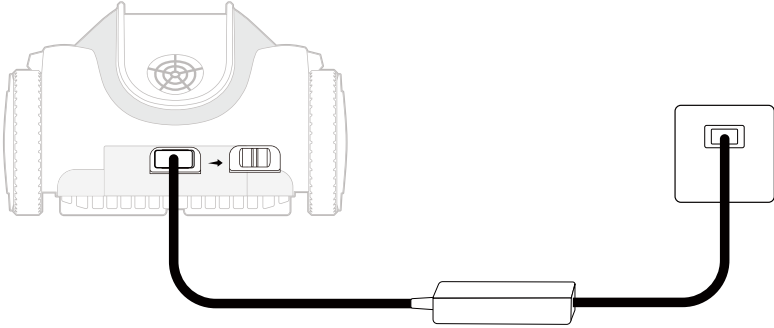

**4.2 Power On:** Toggle bottom switch to ON.

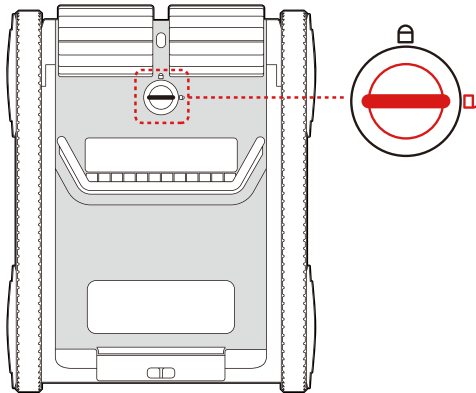

**4.3 Go:** Hold ON/OFF for 3 s. LEDs flash—set options—tap again to start.

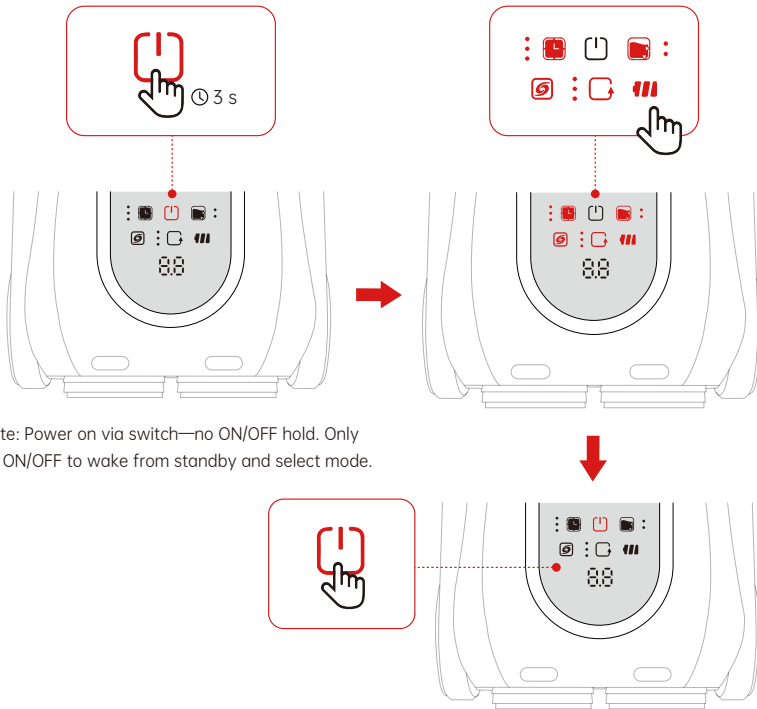

**4.4 Deploy:** Place cleaner in water within 3 minutes; rotate to release air.

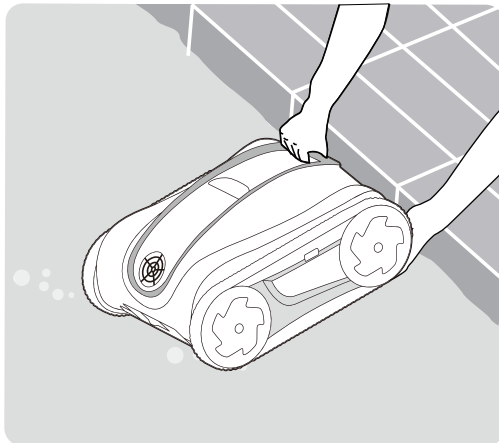

---

**4.5 Prepare:** Attach retrieval hook to a suitable pole (sold separately).

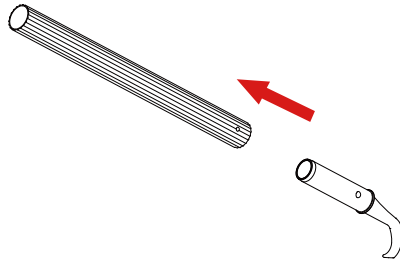



## 5 Connecting Your Cleaner

### 5.1 Before you begin:

- Enable Bluetooth and Wi-Fi on your phone.
- Connect to a 2.4GHz Wi-Fi network with a strong signal. 5G Wi-Fi is not supported.
- Allow Bluetooth access when prompted by the app.

### 5.2 Pairing the robot:

1. Hold the (  ) button for 3 seconds.
2. The robot will beep, and the (  ) light will begin flashing.
3. Open the iGarden Robotics app to complete pairing.
4. A confirmation will appear once pairing is successful.

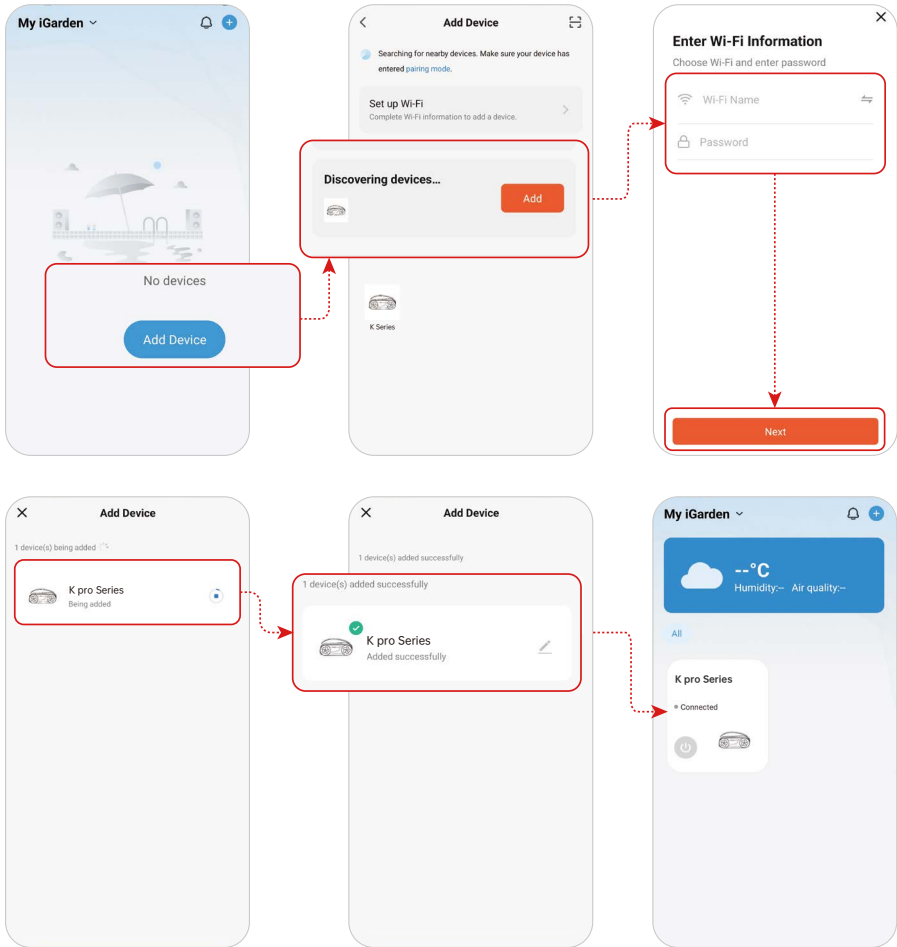

**💡 Notes:**

- App control is available via 2.4G Wi-Fi (5G Wi-Fi not supported) or Bluetooth.
- App functions are unavailable while the robot is in the pool due to signal interference.
- Download iGarden Robotics from the App Store or Google Play.

## 6 Using Your Cleaner

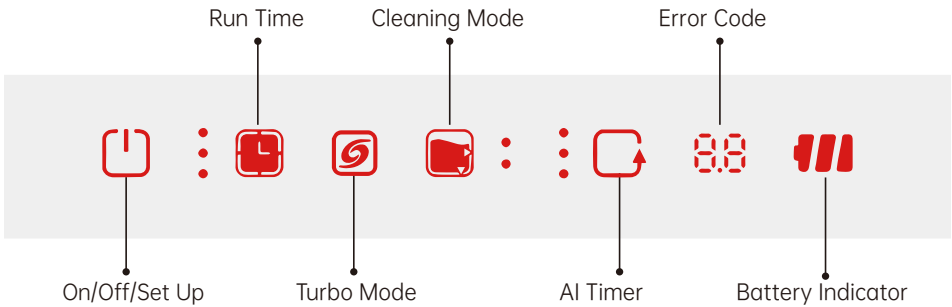

### 6.1 Control Panel Overview

Button	Icon	Display	Function
On/Off/Set Up		Light Flashes / On	Wake/Sleep, Confirm Settings
Run Time		1 / 2 / 3 LEDs or Off	1 h / 1.5 h / 2 h / Run Until Low Battery
Turbo Mode		Green On / Off	High-Power Boost / Standard
Cleaning Mode		Bottom LED On	Floor Only
		Top LED On	Wall & Waterline Only
		*Both LEDs On	*Wall & Waterline first, then Floor
		*Both LEDs Off	*Full Coverage
AI Timer		1 / 2 / 3 LEDs or Off	Auto-Clean Every 24 / 48 / 72 h / Disabled
Error Code		E1-E6	System Fault (see Troubleshooting)
Battery Indicator		Green / Red LEDs	20-100 % / < 20 % Charge Levels

#### \*Important Cleaning Modes Explained

##### Wall & Waterline first, then Floor

Recommended for most cleaning needs; Does not clean tanning ledges or other shallow areas.

##### Full Coverage

Cleans Floor → Wall → Waterline to cover all areas (Includes tanning ledges); May use more power than Wall & Waterline first, then floor.

## 6.2 Control Panel Details

Function	Condition	Response
On/Off Hold	3 s	Wake or Sleep Mode
Tap	While Running	Confirm Selected Settings
Low Battery	< 15 %	Red LED Flashes; Parks Then Sleeps
Mode Selection	Press Cycle	Floor Only / All-Surfaces Options

## 7 Care & Cleaning

### Filter Basket

- Clean after each cycle: unlatch, rinse, reinsert.
- Deep-clean with mild acid detergent annually.

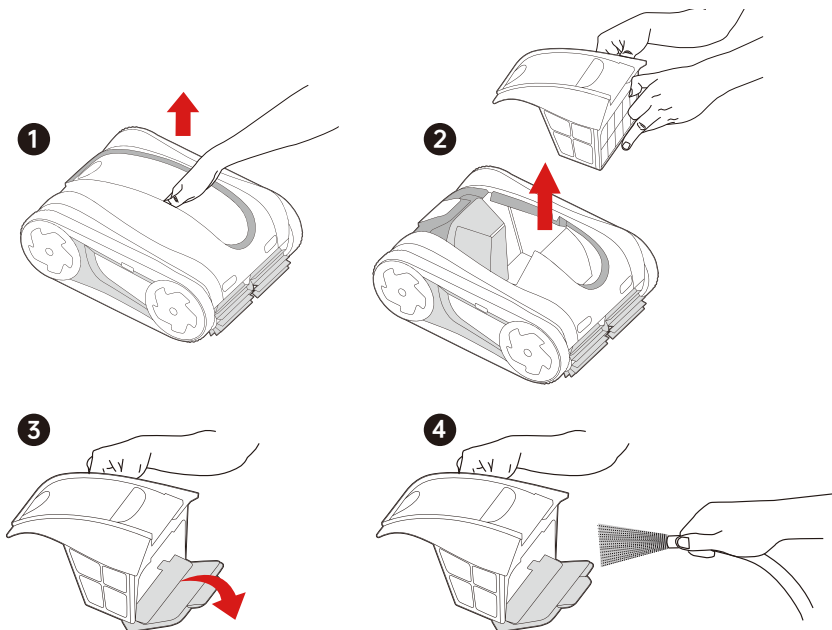

---

## Impeller

1. Switch OFF and unplug.

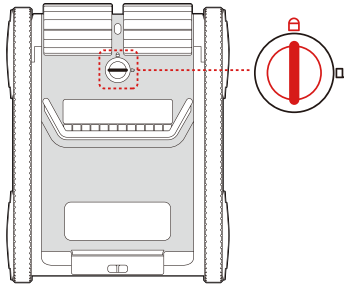

2. Remove filter basket.

3. Unscrew deflector cap; clear debris.

4. Reassemble securely.

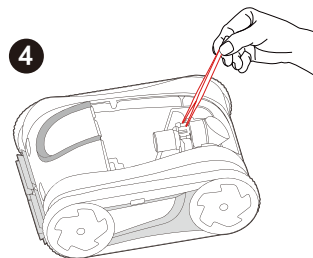
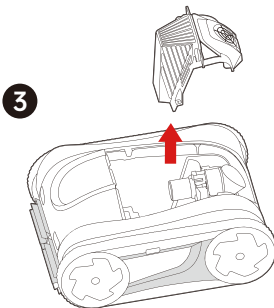
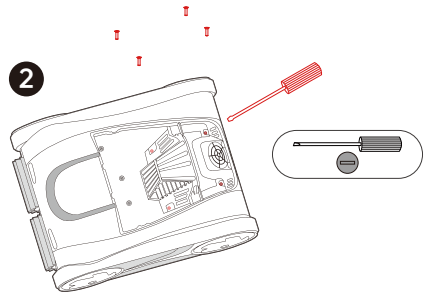
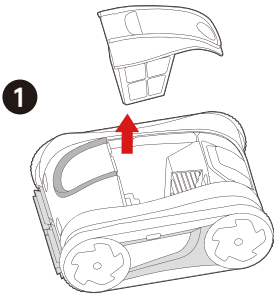

## Brushes & Tracks

Part	Indicator	Action
Brushes	Worn bristles	Release tabs, slide on new brushes

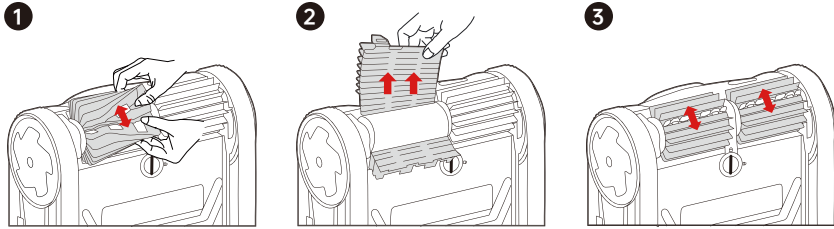

Part	Indicator	Action
Tracks	Slippage/cracks	Pry off hub cover, swap tracks, reassemble

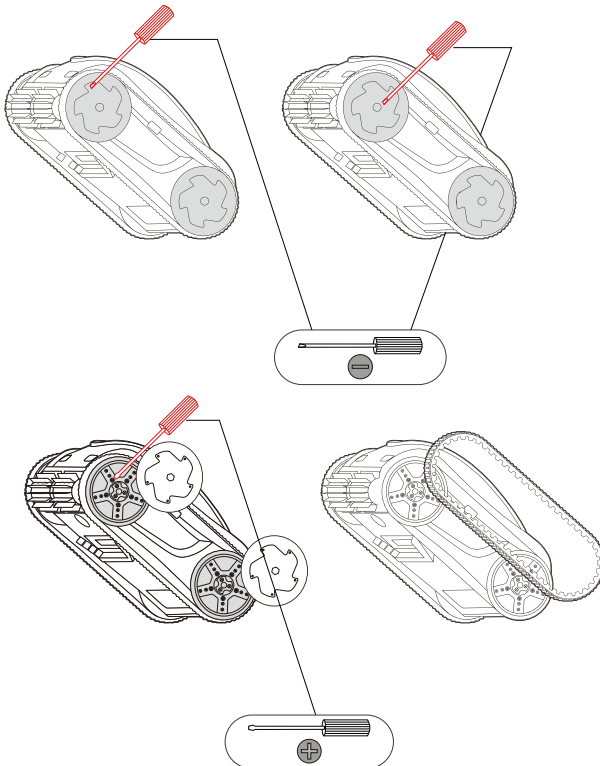

---

## Usage & Care

- Drain and place flat after each use
- Clean filter basket thoroughly; remove all debris

## Operation Protection

- Below 30 % battery: floor cleaning only, then stop
- Five consecutive wall-climb failures → switch to floor mode



## Battery Care

- Charge fully every three months
- If unused for over 14 days, turn off the bottom power switch

## Storage

- Dry completely before storing
- Store at  $-10^{\circ}\text{C}$  to  $45^{\circ}\text{C}$ , 30 %–70 % RH
- Coil cable neatly and avoid twists

## 8 Troubleshooting

Failure	Possible Reasons	Solution
<b>Charging Failure</b>	Debris on charging head	Clean debris
	Damaged charging kit	Replace charging kit
<b>Startup Failure</b>	Water on panel or hands	Wipe dry and retry
	Operational error	Hold ON/OFF for 3s
	Dead battery / Low battery	Fully charge
<b>No Movement/Pump</b>	Out of water	Submerge fully
	Power button not pressed	Tap ON/OFF after setup
<b>Not Working</b>	Full filter basket	Clean the basket
	Impeller stuck	Clear debris in OFF state
<b>Moving but Not Pumping</b>	Full filter basket	Clean basket
	Water inlet clogged	Remove and clean inlet
	Low battery	Fully charge
<b>Pumping but Not Moving</b>	Obstacle entrapment	Remove obstacle and restart
	Worn track/deviation	Roll or replace track
<b>Not Climbing</b>	Impeller stuck	Clear debris
	Full filter basket	Clean basket
	Water inlet clogged	Clean inlet
	Low battery	Fully charge
<b>Poor Cleaning</b>	Worn filter/brush	Replace filter/brush
	Inlet clogged	Clean inlet
<b>Abnormal Operation</b>	Software glitch	Power-cycle OFF → ON
<b>Error Codes</b>	E1-E6	Restart; if persists, support

## 9 Technical Specifications

### Model Comparison

Model	K Pro 100	K Pro 120	K Pro 150
Mode: Floor			
Battery Life	10h	12h	15h
Mode: Full Coverage			
Battery Life	6h	7h	8.5h
Mode: Turbo+Floor			
Battery Life	5.5h	6.5h	8h
Mode: Turbo+Full Coverage			
Battery Life	5h	5.8h	7h
Charging Time	9h	9h	9h
Battery Capacity	14.1Ah (364.2Wh)		
Recommended Maximum Pool Size	8*15m		10*18m
Optimal Pool Temperature	4~35°C		
Cleaning Mode	Floor Only / Wall&Waterline Only / Wall&Waterline first, then Floor / Full Coverage		
Multiple Cycle Option	1 h / 1.5 h / 2 h / Max		
Turbo mode	YES		
AI Timer	24h/48h/72h		
APP	YES		
Filter Capacity	4L		
Filtration Accuracy	Single-layer: 100 µm		
Pump Flow Rate	18m <sup>3</sup> /h-25m <sup>3</sup> /h		20m <sup>3</sup> /h-28m <sup>3</sup> /h
Running Power	20-100W		20-120W

Moving Speed	10-12m/min
Number of Motors	3
Charger Input	100-240VAC ~ 50/60Hz, Type I-3 pin (Australian)
Running Voltage / Current	25.8V/1A
Robot NW / GW	11kg/14.3kg
Product Dimensions (L×W×H)	489*389*240 mm
Package Dimensions (L×W×H)	580*450*330 mm
<b>NOTE:</b> Tested in a pristine 10-ft × 26-ft rectangular pool under controlled lab conditions. Actual battery life may vary with pool size, shape, and water quality.	

## 10 Regulatory & Compliance

### Indoor Charging Only

Charge the cleaner indoors in a dry area away from direct sunlight.

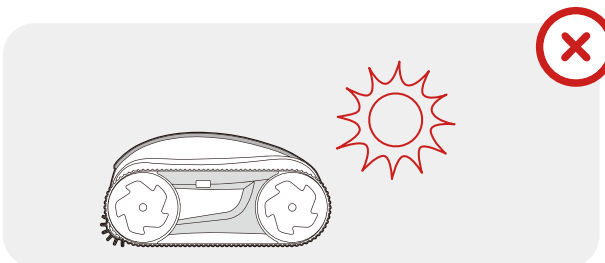
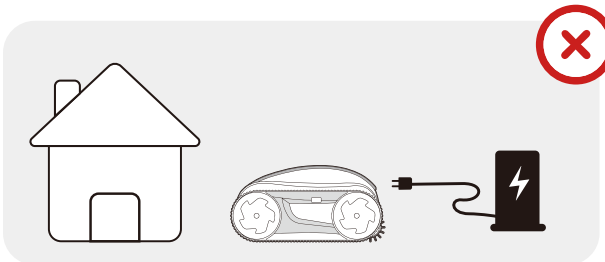

---

## Battery Recycling

The unit contains a lithium-ion battery. Recycle batteries at qualified facilities. Recycling batteries benefits the environment and public health. Do not disassemble or dispose of batteries in household trash or municipal recycling bins.

For complete regulatory statements (FCC Caution, FCC Statement, IC Statement) and manufacturer information, visit: <https://store.igarden.ai/pages/warranty-policy>

## 11 Warranty

**Full Unit (motor, battery, electronics):** 3 years

**Consumables (brushes, baskets, filters, tracks):** 6 months

Our goods come with guarantees that cannot be excluded under the Australian Consumer Law. You are entitled to a replacement or refund for a major failure and compensation for any other reasonably foreseeable loss or damage. You are also entitled to have the goods repaired or replaced if the goods fail to be of acceptable quality and the failure does not amount to a major failure.

For complete warranty terms—including exclusions, service process, and limitations—please visit: <https://store.igarden.ai/pages/warranty-policy>

## 12 Support



Email: [support@igarden.ai](mailto:support@igarden.ai) (US & AU)  
[support.eu@igarden.ai](mailto:support.eu@igarden.ai) (EU)



Official Website: [www.igarden.ai](http://www.igarden.ai)



Facebook: iGarden



Toll-free(US): (+1)888-880-3320  
Toll-free(AU): (+61)1800-716-885

© 2025 iGarden All rights reserved. Version AMZ-K Pro-Manual-V4.3 (EN)

Full legal terms and updated specs: <https://store.igarden.ai/pages/warranty-policy>



# iGarden

 [www.igarden.ai](http://www.igarden.ai)

Version: AMZ-K Pro-Manual-V4.3 (EN)

Thank you for choosing our Cordless Robotic Pool Cleaner.